

NOS Centrifugal Pump 45kw

NOS

Specification

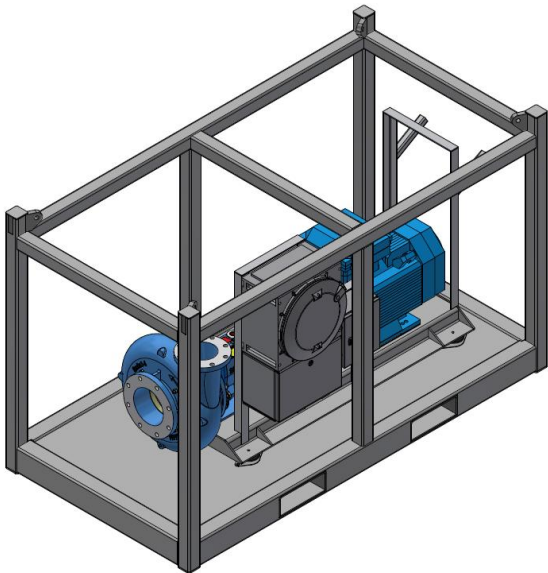

NOS C-Pumps are Efficient and easy to use transfer pumps made for use in ATEX zone 1 areas.

C-Pump on Frame

Approvals	Norsok Z-015, SNV 2.7-1	
Area Classification	ATEX Sone 1	
Frame Envelope Size	2460 x 1260 x 1468mm (LxWxH)	
M.G.W	3700kg	
Tare	2000 kg	
Max Payload	1700 kg	
Z-015 Type	U99	
Electric motor	45kw 60BHP	
Pump	Mission 2500 5x4x14	
Flow & pressure		
	12in impeller	14in impeller
Capacity @50 hz	3785 lpm	2450 lpm
Capacity @60 hz	4542 lpm	2940 lpm
NPSH @ Max Capacity	29 feet	8 feet
WP / MAX Head	5 bar/50m	6 bar/64m
Supply connection		
Pump Priming	NOT self-priming	
Outlet	4" FIG 206	
Inlet	4" FIG 206	
Power	440v, 125A-690v, 63A	
Ambient Operating temperature	0 – 60 °C (below 0°C contact NOS)	



NOS Centrifugal Pump 45kw

Pump Curves

NOS

Magnum I
5X4X14
Speed: 1750 RPM
Curve: 951

Open Impeller
Dia: 7" to 14"
Eye Area: 19.6 Sq. In.
Max Sphere: 13/32 In.

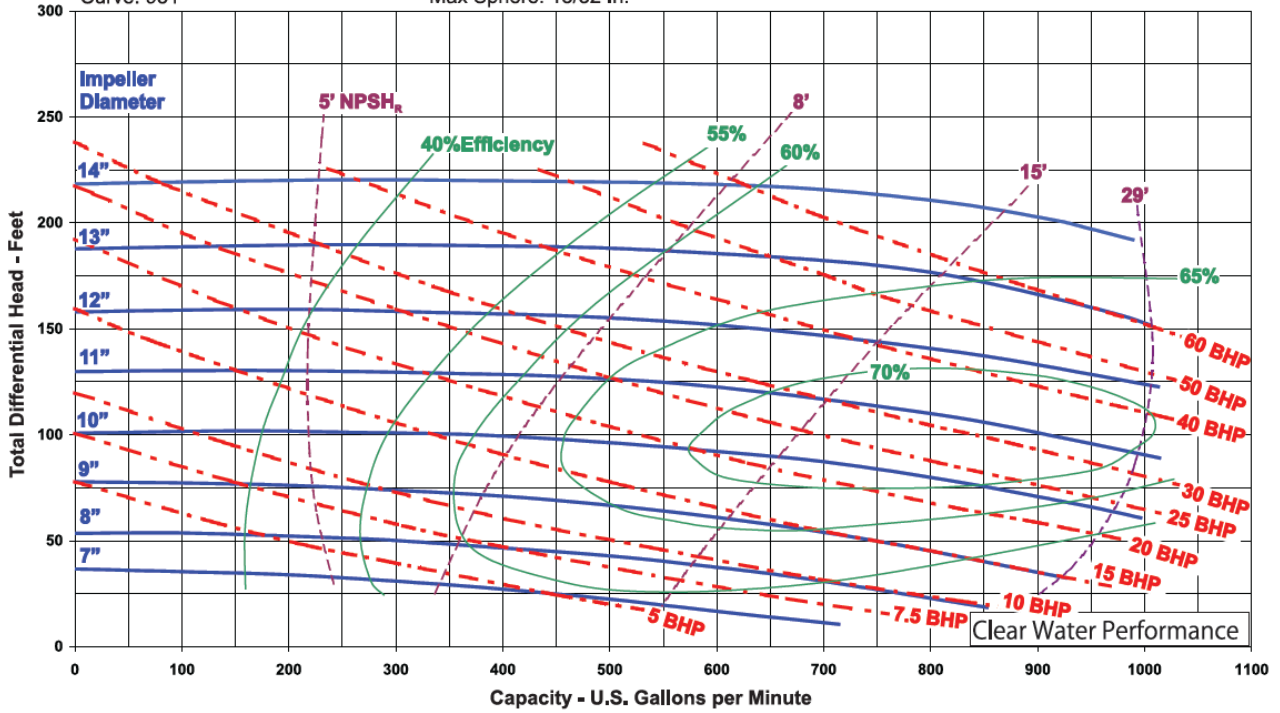

Magnum I
5X4X14
Speed: 800-2100 RPM
Curve: 978

Open Impeller
Dia: 14"
Eye Area: 19.6 Sq. In.
Max Sphere: 13/32 In.

