

# NOS Centrifugal Pump 55kw

# NOS

## Specification

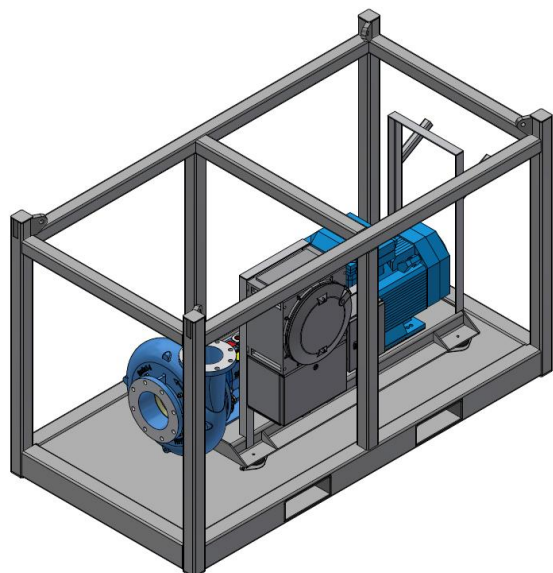

NOS C-Pumps are Efficient and easy to use transfer pumps made for use in ATEX zone 1 areas.

### C-Pump on Frame

<b>Approvals</b>	Norsok Z-015, SNV 2.7-1
<b>Area Classification</b>	ATEX Sone 1
<b>Frame Envelope Size</b>	2460 x 1260 x 1468mm (LxWxH)
<b>M.G.W</b>	3700kg
<b>Tare</b>	2000 kg
<b>Max Payload</b>	1700 kg
<b>Z-015 Type</b>	U99
<b>Electric motor</b>	55kw 75BHP
<b>Pump</b>	Mission 2500 6x5x14
<b>Flow &amp; pressure</b>	
	14in impeller
<b>Capacity @ 50hz</b>	2950 lpm
<b>Capacity @ 60hz</b>	3540 lpm
<b>NPSH @ Max Capacity</b>	2m
<b>WP / MAX Head</b>	6 bar/64m
<b>Supply connection</b>	
<b>Pump Priming</b>	NOT self-priming
<b>Outlet</b>	4" FIG 206
<b>Inlet</b>	4" FIG 206
<b>Power</b>	440v, 125A-690v, 63A
<b>Ambient Operating temperature</b>	0 – 60 °C (below 0°C contact NOS)



# NOS Centrifugal Pump 55kw

# NOS

## Pump Curves

